

# THREE-WAY MIXING CONTROL VALVES CE

## PED 97/23/CE / ATEX 94/9/CE / MACHINERY DIRECTIVE 2006/42/CE

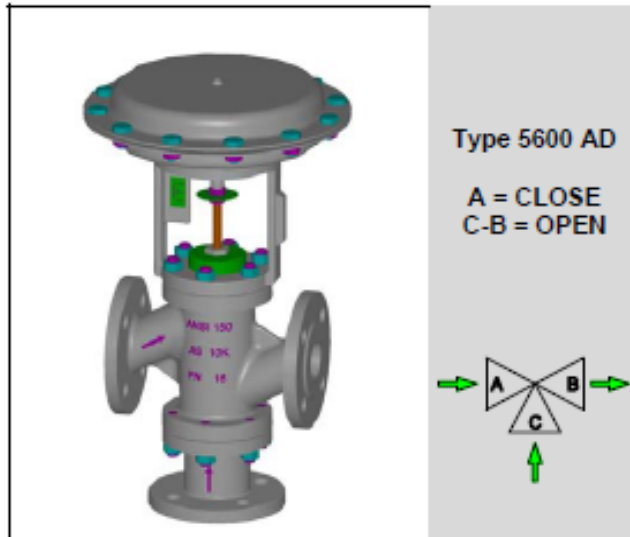

**TYPE 5600 AD DN 15/100**  
Normally closed port "A" on air failure

Face-to-face ASME / ANSI B16.10

### DESCRIPTION

The "UNIWORLD" series type 5600 AD are equipped with "straight-through" pattern bodies having ANSI face-to-face dimensions and EN - ANSI - JIS flanges.

Type 5600 AD three-way mixing control valves (two inlet ports and one outlet port with fluid opens) have a modulating plug suitable for control of virtually all line media.

Compact construction assembled with multisprings pneumatic actuator having 3-15 psi ... 6-18 psi ... 6-30 psi standard control signals

On request can be equipped with a pneumatic or electro-pneumatic pilot positioner.

**SIZES :** from DN 15 to DN 100

**BODY CONNECTIONS :** flanged EN 1092-1 PN16 PN40  
flanged ANSI B 16.5 150 RF 300 RF  
flanged JIS B2220 10K 20K

**MATERIALS OF BODY GROUP (1) :**

- Cast iron EN-GJL-250 UNI EN 1561 PN 16 ANSI 150 JIS 10  
AISI 316 st. st. trim - C40 nickel plated steel bonnet
- Carbon steel ASTM A216 WCB PN16/40 ANSI 150/300 JIS10/20  
AISI 316 st. st. trim - C40 nickel plated steel bonnet
- Stainless steel AISI 316 CF8M PN16/40 ANSI 150/300 JIS10/20  
AISI 316 st. st. trim - AISI 316 st. st. bonnet

**PLUG**

- PL (DN15-20) LV (DN25-100) = linear class IV\*
- PT (DN15-20) VPT (DN25-100) = quick lift class IV\*

**BONNET (2) :**

- Standard : -5 to +200 °C
- Finned : >200 °C
- Extended : below -5 °C
- Bellows sealed : for thermal oil or hazardous media with  
(PN 16 - 25 - 40) standard safety gland arrangement

**GLAND ARRANGEMENT (PACKING) (3) with safety "O-rings" :**

- PTFE 100% for temperatures ≤150 °C
- PTFE 85% + GRAPHITE 15% for temperatures ≤200 °C
- PURE GRAPHITE 100% for temperatures from 200° to 400 °C  
to be used with finned bonnet

**CV = american unit (flowrate in USGPM with 1 psi of differential pressure)**

### TECHNICAL CHARACTERISTICS OF PNEUMATIC ACTUATOR :

- Actuator : diaphragm type
- Control signals : 3-15 psi ... 6-18 psi ... 6-30 psi
- Max air supply pressure : 35 psi (2,5 bar)
- Ambient temperature : -20 ... +70 °C \*see on request
- Actuator casings material : Fe P11 carbon steel
- Diaphragm material : EPDM 70
- Yoke material : EN-GJS500-7 spheroidal cast iron
- Pneumatic connections : ISO 7 Rp - 1/8"

**MAX WORKING**

**CONDITIONS :**

- Max inlet pressure and temperature : see leaflet n° 101/VP
- Valve sizing : see leaflet n° 100/VP
- Rangeability : see leaflet n° GRAFIC/II

**ON REQUEST :**

- PTFE/GR soft seal ≤190°C class VI\*
- PTFE soft seal ≤150°C class VI\*
- Lapping on seat and plug class V\*
- Stellite (degree 6°) on seat and plug and guide bush
- Reduced bore (see below table)
- Pneumatic pilot positioner 3-15 psi...3-9 psi...9-15 psi
- Electro-pneumatic pilot positioner 4-20 mA...4-12 mA...12-20 mA
- Air filter regulator
- Proximity limit switches
- 3-way solenoid valve
- Lubrificator on finned bonnet for temperatures ≥250 °C
- Top-work manual handwheel
- ATEX 94/9/CE dedicated configuration according to the fluid
- Kit diaphragm and actuator seals certified for a.t. ≥ -50 °C

**Kv = metric unit (flowrate in m3/h with 1 bar of differential pressure)**

PLUG		DN15	DN 20	DN25	DN32	DN40	DN50	DN65	DN80	DN100
Full bore		Ø 1/2"	Ø 3/4"	Ø 1"	Ø 1.1/4"	Ø 1.1/2"	Ø 2"	Ø 2.1/2"	Ø 3"	Ø 4"
PL	CV	3.4	6.6	10	23.4	28	36.4	72.7	89.3	123.8
	KV	2.9	5.7	8.6	20.1	24.1	31.4	62.7	77	106.7
PT	CV	3.4	6.6	13.8	30.3	38.7	52	99.6	116.2	162.4
	KV	2.9	5.7	11.9	26.1	33.4	44.8	85.8	100.1	140
Reduced bore *		n.a.	1/2"	1/2" 3/4"	3/4" 1"	1" 1.1/4"	1.1/4" 1.1/2"	1.1/2" 2"	2" 2.1/2"	2.1/2" 3"

n.a. = not applicable

\* CV and KV values are referred to the selected diameter and plug type (PL/LV only)

**Maximum permissible pressure drops in Kg/cm<sup>2</sup> (fluid opens)  
Strokes in mm – Signals in psi**

Actuator type	Signal psi	DN15	DN20	DN25	DN32	DN40	DN50	DN65	DN80	DN100
		Stroke 11	Stroke 11	Stroke 11	Stroke 18	Stroke 18	Stroke 18	Stroke 28	Stroke 28	Stroke 28
T200	3-15 psi	12	8	5	3	-	-	-	-	-
	6-18 psi	25	18	9	5.2	-	-	-	-	-
	6-30 psi	65	40	22	11	-	-	-	-	-
T250	3-15 psi	27	17	9	6	4	2.4	-	-	-
	6-18 psi	55	34	19	12	8	3	-	-	-
	6-30 psi	110	68	38	20	14.5	7	-	-	-
T310	3-15 psi	-	-	15.5	10	7	3.5	2.5	1.7	0.9
	6-18 psi	-	-	31	20	14	7	4.2	2.8	1.3
	6-30 psi	-	-	62	30	21	12	6.5	4.7	2.6
T400	3-15 psi	-	-	-	14.5	10.5	5	3.8	2.5	1.4
	6-18 psi	-	-	-	29.5	20.5	12	6.7	4	2.8
	6-30 psi	-	-	-	45	31.5	18	16	11	6.3
T500	3-15 psi	-	-	-	24.5	17.5	9.5	5.5	4.2	2.4
	6-18 psi	-	-	-	49	34.5	19.5	12.2	7	4.9
	6-30 psi	-	-	-	75	52.5	30.3	26	16	10.5

1. The values given are referred to the force of actuator and they can be used within the limit of the body rating
2. The actuator DELTA-PI (PRESSURE DROPS with CLOSED VALVE) are obtained without a residual thrust of air into the actuator
3. The actuator DELTA-PI given in the column 6-30 psi are also valid for ON-OFF service with air supply at 30/35 psi

**COMPONENTS LIST AND MATERIALS**

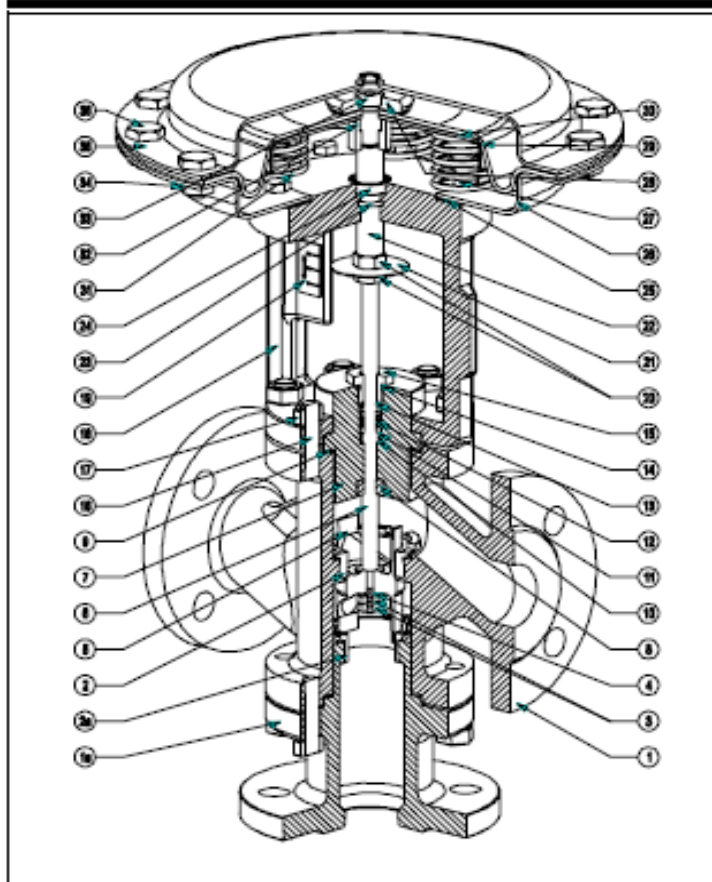

**COMPONENTS LIST**

1. Body
- 1a. Stud pipe
2. Upper seat
- 2a. Lower seat
3. Plug locknuts
4. Spring washer
5. Plug
6. Stem
7. Bonnet
8. Guide bush
9. Body gasket
10. Packing spring
11. Packing washer
12. Packing rings
13. Internal "O" ring
14. External "O" ring
15. Packing adjusting nut
16. Stud-bolts
17. Body locknuts
18. Yoke
19. Travel indicator plate
20. Position indicator locknuts
21. Position indicator
22. Diaphragm rod
23. "O" ring
24. Airtight
25. Yoke gasket
26. Lower diaphragm casing
27. Lower diaphragm casing internal bolts
28. Diaphragm spacer
29. Diaphragm
30. Diaphragm plate
31. Springs
32. Diaphragm bush
33. Diaphragm locknut
34. Diaphragm casing bolts
35. Upper diaphragm casing
36. Diaphragm casing locknuts

**MATERIALS**

1. See note (1) at page 1
- 1a. C40 carbon steel
2. AISI 316 stainless steel
- 2a. AISI 316 stainless steel
3. AISI 304 stainless steel
4. AISI 304 stainless steel
5. AISI 316 stainless steel
6. AISI 316 stainless steel
7. See note (1)-(2) at page 1
8. AISI 304 stainless steel
9. Europil WS 3640 or PTFE
10. AISI 302 stainless steel
11. AISI 304 stainless steel
12. See note (3) at page 1
13. Viton FPM 70
14. Viton FPM 70
15. AISI 303 stainless steel
16. Galvanized steel
17. DIN 934 galvanized steel
18. GGG50 spheroidal c. iron
19. Polycarbonate
20. DIN 936 galvanized steel
21. Aluminium
22. AISI 303 stainless steel
23. NBR
24. NBR
25. Cork – rubber
26. P11 steel
27. DIN 933 galvanized steel
28. Galvanized steel
29. EPDM 70
30. P01 steel
31. C98 UNI 3823
32. AISI 303 stainless steel
33. ISO 7380 galvanized steel
34. DIN 934 galvanized steel
35. P11 steel
36. DIN 933 galvanized steel

**DIMENSIONS in mm.**

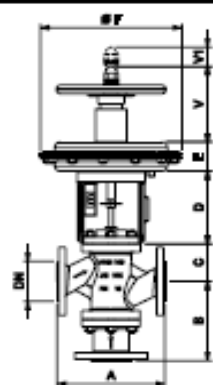

DN	Ø	A(1)	A(2)	B	C - Bonnet			D	V	V1
					Std	Finned	Bellows			
15	1/2"	184	190	132	49	181	181	147	166	11
20	3/4"	184	194	134	58	190	190	147	166	11
25	1"	184	197	135	68	200	200	147	166	11
32	1.1/4"	200	212	134	70	202	202	147	166	19
40	1.1/2"	222	235	165	82	214	214	160	166	19
50	2"	254	267	185	88	218	218	160	166	19
65	2.1/2"	276	292	220	111	309	309	160	166	28
80	3"	298	317	222	135	333	333	160	166	28
100	4"	352	368	241	160	383	383	204	166	28

Actuator	E	Ø F
200	70	210
250	70	292
310	95	336
400	119	408
500	119	520

A(1) cast iron = PN16-ANSI150-JIS10K A(2) carbon and st. steel = PN16-PN40-ANSI150-ANSI300-JIS10K – JIS20K  
Specifications given are only indicative and not binding for the manufacturer who reserve the right to carry-out any modifications deemed necessary without prior notice. All data sheets by CONFLOW SpA, are available last updates on our internet web site [www.conflow.it](http://www.conflow.it).

**THREE-WAY MIXING CONTROL VALVES** CE  
**PED 97/23/CE / ATEX 94/9/CE / MACHINERY DIRECTIVE 2006/42/CE**

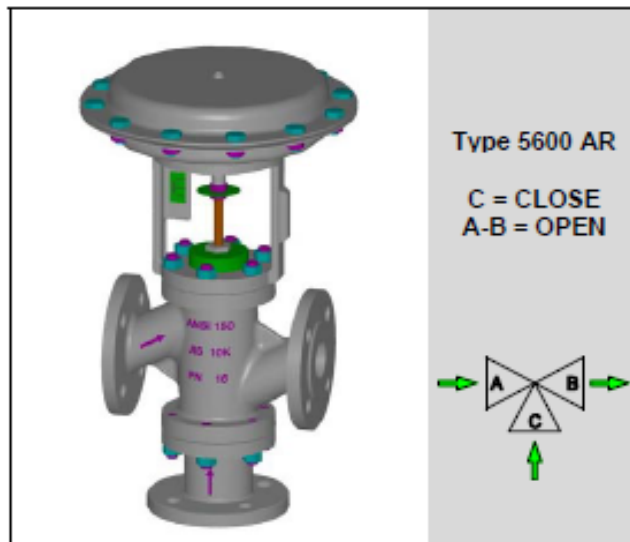

**TYPE 5600 AR DN 15/100**  
 Normally closed port "C" on air failure

Face-to-face ASME / ANSI B16.10

**DESCRIPTION**

The "UNIWORLD" series type 5600 AR are equipped with "straight-through" pattern bodies having ANSI face-to-face dimensions and EN – ANSI – JIS flanges.  
 Type 5600 AR three-way mixing control valves (two inlet ports and one outlet port with fluid opens) have a modulating plug suitable for control of virtually all line media.  
 Compact construction assembled with multisprings pneumatic actuator having 3-15 psi ... 6-18 psi ... 6-30 psi standard control signals  
 On request can be equipped with a pneumatic or electro-pneumatic pilot positioner.

**SIZES :** from DN 15 to DN 100

**BODY CONNECTIONS :** flanged EN 1092-1 PN16 PN40  
 flanged ANSI B 16.5 150 RF 300 RF  
 flanged JIS B2220 10K 20K

**MATERIALS OF BODY GROUP (1) :**

- Cast iron EN-GJL-250 UNI EN 1561 PN 16 ANSI 150 JIS 10  
 AISI 316 st. st. trim - C40 nickel plated steel bonnet
- Carbon steel ASTM A216 WCB PN16/40 ANSI 150/300 JIS10/20  
 AISI 316 st. st. trim - C40 nickel plated steel bonnet
- Stainless steel AISI 316 CF8M PN16/40 ANSI 150/300 JIS10/20  
 AISI 316 st. st. trim - AISI 316 st. st. bonnet

**PLUG**

- PL (DN15-20) LV (DN25-100) = linear class IV<sup>o</sup>
- PT (DN15-20) VPT (DN25-100) = quick lift class IV<sup>o</sup>

**BONNET (2) :**

- Standard : -5 to +200 °C
- Finned : > 200 °C
- Extended : below -5 °C
- Bellows sealed : for thermal oil or hazardous media with  
 (PN 16 - 25 - 40) standard safety gland arrangement

**GLAND ARRANGEMENT (PACKING) (3) with safety "0-rings" :**

- PTFE 100% for temperatures ≤150 °C
- PTFE 85% + GRAPHITE 15% for temperatures ≤200 °C
- PURE GRAPHITE 100% for temperatures from 200° to 400 °C  
 to be used with finned bonnet

**CV = american unit (flowrate in USGPM with 1 psi of differential pressure)**

**TECHNICAL CHARACTERISTICS OF PNEUMATIC ACTUATOR :**

- Actuator : diaphragm type
- Control signals : 3-15 psi ... 6-18 psi ... 6-30 psi
- Max air supply pressure : 35 psi (2,5 bar)
- Ambient temperature : -20 ... +70 °C \*see on request
- Actuator casings material : Fe P11 carbon steel
- Diaphragm material : EPDM 70
- Yoke material : EN-GJS500-7 spheroidal cast iron
- Pneumatic connections : ISO 7 Rp – 1/8"

**MAX WORKING CONDITIONS :**

- Max inlet pressure and temperature : see leaflet n° 101/VP
- Valve sizing : see leaflet n° 100/VP
- Rangeability : see leaflet n° GRAFIC/I

**ON REQUEST :**

- PTFE/GR soft seal ≤190°C class VI<sup>o</sup>
- PTFE soft seal ≤150°C class VI<sup>o</sup>
- Lapping on seat and plug class V<sup>o</sup>
- Stellite (degree 6°) on seat and plug and guide bush
- Reduced bore (see below table)
- Pneumatic pilot positioner 3-15 psi...3-9 psi...9-15 psi
- Electro-pneumatic pilot positioner 4-20 mA...4-12 mA...12-20 mA
- Air filter regulator
- Proximity limit switches
- 3-way solenoid valve
- Lubrifier on finned bonnet for temperatures ≥ 250 °C
- Top-work manual handwheel
- ATEX 94/9/CE dedicated configuration according to the fluid
- Kit diaphragm and actuator seals certified for a.t. ≥ - 50 °C

**Kv = metric unit (flowrate in m3/h with 1 bar of differential pressure)**

PLUG	Full bore	DN15	DN 20	DN25	DN32	DN40	DN50	DN65	DN80	DN100
		Ø 1/2"	Ø 3/4"	Ø 1"	Ø 1.1/4"	Ø 1.1/2"	Ø 2"	Ø 2.1/2"	Ø 3"	Ø 4"
PL	CV	3.4	6.6	10	23.4	28	36.4	72.7	89.3	123.8
	KV	2.9	5.7	8.6	20.1	24.1	31.4	62.7	77	106.7
PT	CV	3.4	6.6	13.8	30.3	38.7	52	99.8	116.2	162.4
	KV	2.9	5.7	11.9	26.1	33.4	44.8	85.8	100.1	140
Reduced bore *		n.a.	1/2"	1/2" 3/4"	3/4" 1"	1" 1.1/4"	1.1/4" 1.1/2"	1.1/2" 2"	2" 2.1/2"	2.1/2" 3"

n.a. = not applicable

\* CV and KV values are referred to the selected diameter and plug type (PL/LV only)

**Maximum permissible pressure drops in Kg/cm<sup>2</sup> (fluid opens)  
Strokes in mm – Signals in psi**

Actuator type	Signal psi	DN15	DN20	DN25	DN32	DN40	DN50	DN65	DN80	DN100
		Stroke 11	Stroke 11	Stroke 11	Stroke 18	Stroke 18	Stroke 18	Stroke 28	Stroke 28	Stroke 28
T200	3-15 psi	12	8	5	3	-	-	-	-	-
	6-18 psi	25	16	9	5.2	-	-	-	-	-
	6-30 psi	65	40	22	11	-	-	-	-	-
T250	3-15 psi	27	17	9	6	4	2.4	-	-	-
	6-18 psi	55	34	19	12	8	3	-	-	-
	6-30 psi	110	68	38	20	14.5	7	-	-	-
T310	3-15 psi	-	-	15.5	10	7	3.5	2.5	1.7	0.9
	6-18 psi	-	-	31	20	14	7	4.2	2.8	1.3
	6-30 psi	-	-	62	30	21	12	6.5	4.7	2.6
T400	3-15 psi	-	-	-	14.5	10.5	5	3.8	2.5	1.4
	6-18 psi	-	-	-	29.5	20.5	12	6.7	4	2.8
	6-30 psi	-	-	-	45	31.5	18	16	11	6.3
T500	3-15 psi	-	-	-	24.5	17.5	9.5	5.5	4.2	2.4
	6-18 psi	-	-	-	49	34.5	19.5	12.2	7	4.0
	6-30 psi	-	-	-	75	52.5	30.3	26	16	10.5

1. The values given are referred to the force of actuator and they can be used within the limit of the body rating
2. The actuator DELTA-PI (PRESSURE DROPS with CLOSED VALVE) are obtained without a residual thrust of air into the actuator
3. The actuator DELTA-PI given in the column 6-30 psi are also valid for ON-OFF service with air supply at 30/35 psi

**COMPONENTS LIST AND MATERIALS**

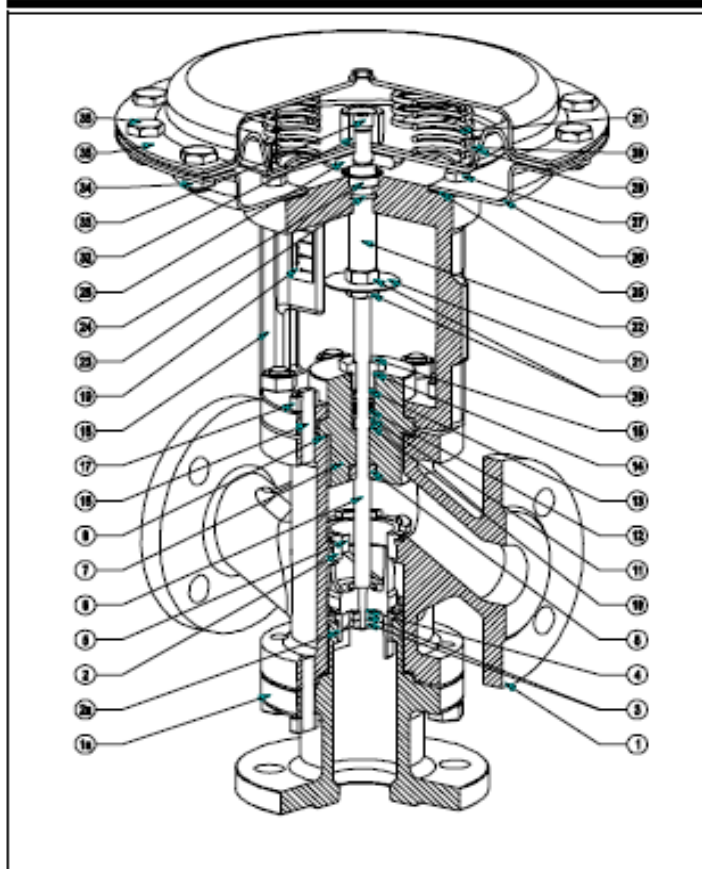

**COMPONENTS LIST**

1. Body
- 1a. Stud pipe
2. Upper seat
- 2a. Lower seat
3. Plug locknuts
4. Spring washer
5. Plug
6. Stem
7. Bonnet
8. Guide bush
9. Body gasket
10. Packing spring
11. Packing washer
12. Packing rings
13. Internal "O" ring
14. External "O" ring
15. Packing adjusting nut
16. Stud-bolts
17. Body locknuts
18. Yoke
19. Travel indicator plate
20. Position indicator locknuts
21. Position indicator
22. Diaphragm rod
23. "O" ring
24. Airtight
25. Yoke gasket
26. Lower diaphragm casing
27. Lower diaphragm casing internal bolts
28. Diaphragm spacer
29. Diaphragm
30. Diaphragm plate
31. Springs
32. Diaphragm bush
33. Diaphragm locknut
34. Diaphragm casing bolts
35. Upper diaphragm casing
36. Diaphragm casing locknuts

**MATERIALS**

1. See note (1) at page 1
- 1a. C40 carbon steel
2. AISI 316 stainless steel
- 2a. AISI 316 stainless steel
3. AISI 304 stainless steel
4. AISI 304 stainless steel
5. AISI 316 stainless steel
6. AISI 316 stainless steel
7. See note (1)-(2) at page 1
8. AISI 304 stainless steel
9. Europil WS 3640 or PTFE
10. AISI 302 stainless steel
11. AISI 304 stainless steel
12. See note (3) at page 1
13. Viton FPM 70
14. Viton FPM 70
15. AISI 303 stainless steel
16. Galvanized steel
17. DIN 934 galvanized steel
18. GGG50 spheroidal c. iron
19. Polycarbonate
20. DIN 936 galvanized steel
21. Aluminium
22. AISI 303 stainless steel
23. NBR
24. NBR
25. Cork – rubber
26. P11 steel
27. DIN 933 galvanized steel
28. Galvanized steel
29. EPDM 70
30. P01 steel
31. C98 UNI 3823
32. AISI 303 stainless steel
33. ISO 7380 galvanized steel
34. DIN 934 galvanized steel
35. P11 steel
36. DIN 933 galvanized steel

**DIMENSIONS in mm.**

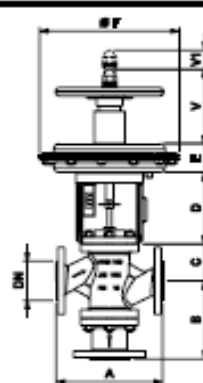

DN	Ø	A(1)	A(2)	B	C - Bonnet			D	V	V1
					Std	Finned	Belows			
15	1/2"	184	190	132	49	181	181	147	166	11
20	3/4"	184	194	134	58	190	190	147	166	11
25	1"	184	197	135	68	200	200	147	166	11
32	1.1/4"	200	212	134	70	202	202	147	166	19
40	1.1/2"	222	235	165	82	214	214	160	166	19
50	2"	254	267	185	86	218	218	160	166	19
65	2.1/2"	276	292	220	111	309	309	160	166	28
80	3"	298	317	222	135	333	333	160	166	28
100	4"	352	368	241	160	363	363	204	166	28

Actuator	E	Ø F
200	70	210
250	70	292
310	95	336
400	119	408
500	119	520

A(1) cast iron = PN16-ANSI150-JIS10K A(2) carbon and st. steel = PN16-PN40-ANSI150-ANSI300-JIS10K - JIS20K  
Specifications given are only indicative and not binding for the manufacturer who reserve the right to carry-out any modifications deemed necessary without prior notice. All data sheets by CONFLOW SpA, are available last update on our Internet web site [www.conflow.it](http://www.conflow.it).

**THREE-WAY MIXING CONTROL VALVES**   
**PED 97/23/CE / ATEX 94/9/CE / MACHINERY DIRECTIVE 2006/42/CE**

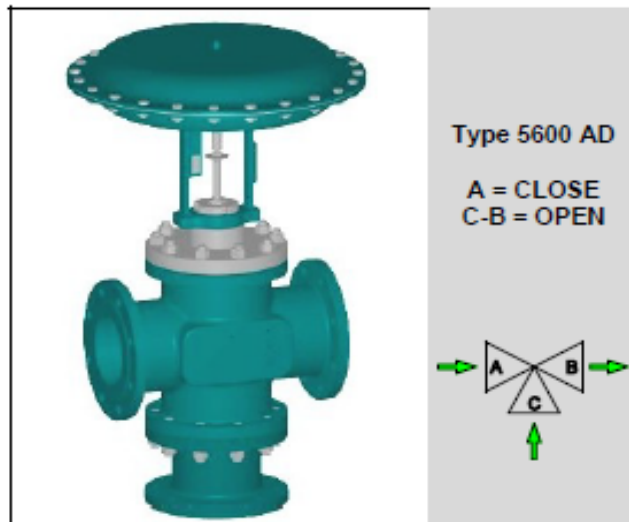

Type 5600 AD

A = CLOSE  
C-B = OPEN

**TYPE 5600 AD DN 125/200**

Normally closed port "A" on air failure

Face-to-face ASME / ANSI B16.10

**DESCRIPTION**

The "UNIWORLD" series type 5600 AD are equipped with "straight-through" pattern bodies having ANSI face-to-face dimensions and EN - ANSI - JIS flanges.

Type 5600 AD three-way mixing control valves (two inlet ports and one outlet port with fluid opens) have a modulating plug suitable for control of virtually all line media.

Compact construction assembled with multisprings pneumatic actuator having 3-15 psi ... 6-18 psi ... 6-30 psi standard control signals

On request can be equipped with a pneumatic or electro-pneumatic pilot positioner.

**SIZES :** from DN 100 to DN 200

**BODY CONNECTIONS :** flanged EN 1092-1 PN16 PN40  
flanged ANSI B 16.5 150 RF 300 RF  
flanged JIS B2220 10K 20K

**MATERIALS OF BODY GROUP (1) :**

- Cast iron EN-GJL-250 UNI EN 1561 PN 16 ANSI 150 JIS 10  
AISI 316 st. st. trim - C40 nickel plated steel bonnet
- Carbon steel ASTM A216 WCB PN16/40 ANSI 150/300 JIS10/20  
AISI 316 st. st. trim - C40 nickel plated steel bonnet
- Stainless steel AISI 316 CF8M PN16/40 ANSI 150/300 JIS10/20  
AISI 316 st. st. trim - AISI 316 st. st. bonnet

**PLUG**

- LV = linear class IV\*
- VPT = quick lift class IV\*

**BONNET (2) :**

- Standard : -5 to +200 °C
- Finned : > 200 °C
- Extended : below -5 °C
- Bellows sealed : for thermal oil or hazardous media with  
(PN 16 - 25 - 40) standard safety gland arrangement

**GLAND ARRANGEMENT (PACKING) (3) with safety "O-rings" :**

- PTFE 100% for temperatures ≤150 °C
- PTFE 85% + GRAPHITE 15% for temperatures ≤ 200 °C
- PURE GRAPHITE 100% for temperatures from 200° to 400 °C  
to be used with finned bonnet

**CV = american unit (flowrate in USGPM with 1 psi of differential pressure)**

**TECHNICAL CHARACTERISTICS OF PNEUMATIC ACTUATOR :**

- Actuator : diaphragm type
- Control signals : 3-15 psi ... 6-18 psi ... 6-30 psi
- Max air supply pressure : 35 psi (2,5 bar)
- Ambient temperature : -20 ... +70 °C \*see on request
- Actuator casings material : Fe P11 carbon steel
- Diaphragm material : EPDM 70
- Yoke material : EN-GJS500-7 spheroidal cast iron
- Pneumatic connections : ISO 7 Rp - 1/8"

**MAX WORKING**

**CONDITIONS :**

- Max inlet pressure and temperature : see leaflet n° 101/VP
- Valve sizing : see leaflet n° 100/VP
- Rangeability : see leaflet n° GRAFIC/II

**ON REQUEST :**

- PTFE/GR soft seal ≤190°C class VI\*
- PTFE soft seal ≤150°C class VI\*
- Lapping on seat and plug class V\*
- Stellite (degree 6°) on seat and plug and guide bush
- Reduced bore (see below table)
- Pneumatic pilot positioner 3-15 psi...3-9 psi...9-15 psi
- Electro-pneumatic pilot positioner 4-20 mA...4-12 mA...12-20 mA
- Air filter regulator
- Proximity limit switches
- 3-way solenoid valve
- Lubricator on finned bonnet for temperatures ≥ 250 °C
- Top-work manual handwheel
- ATEX 94/9/CE dedicated configuration according to the fluid
- Kit diaphragm and actuator seals certified for a.t. ≥ -50 °C

**Kv = metric unit (flowrate in m3/h with 1 bar of differential pressure)**

PLUG		DN125		DN150		DN200	
Full bore		Ø 5"		Ø 6"		Ø 8"	
LV	CV	290.9		357.3		578.1	
	KV	250.8		308		498.3	
VPT	CV	355.3		429.8		658.6	
	KV	308.3		370.5		587.7	
Reduced bore *		3"	4"	4"	5"	5"	6"

\* CV and KV values are referred to the selected diameter and plug type

## Maximum permissible pressure drops in Kg/cm<sup>2</sup> (fluid opens)

### Strokes in mm – Signals in psi

Actuator type	Signal psi	DN125		DN150		DN200	
		Stroke 60		Stroke 60		Stroke 60	
T400	3-15 psi	0.9		0.65		0.35	
	6-18 psi	1.85		1.3		1.05	
	6-30 psi	4.5		3.2		1.8	
T500	3-15 psi	1.55		1.1		0.95	
	6-18 psi	3.1		2.2		1.25	
	6-30 psi	5.5		4		2.2	

1. The values given are referred to the force of actuator and they can be used within the limit of the body rating
2. The actuator DELTA-PI (PRESSURE DROPS with CLOSED VALVE) are obtained without a residual thrust of air into the actuator
3. The actuator DELTA-PI given in the column 6-30 psi are also valid for ON-OFF service with air supply at 30/35 psi

## COMPONENTS LIST AND MATERIALS

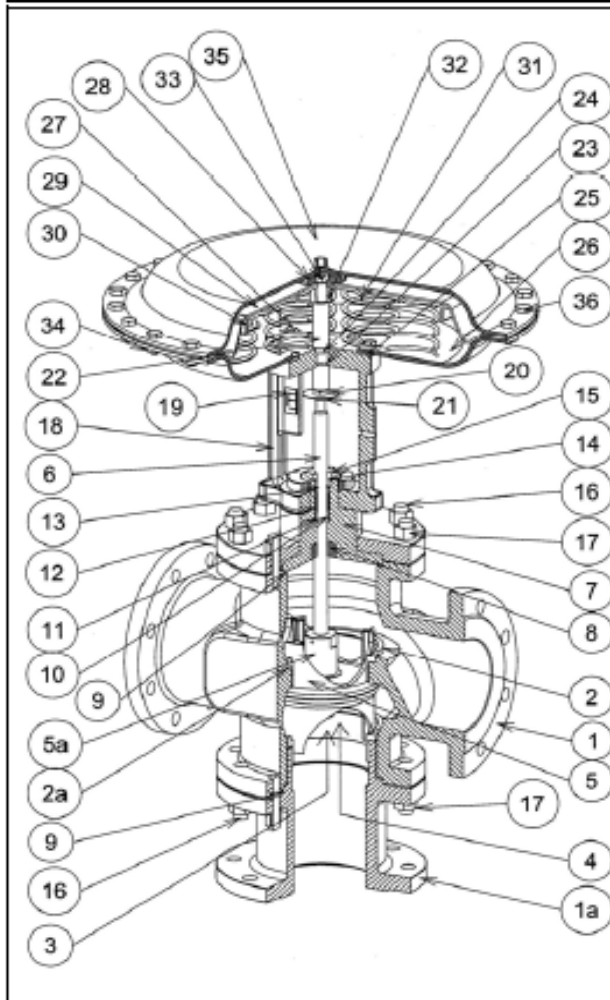

### COMPONENTS LIST

1. Body
- 1a. Stud pipe
2. Upper seat
- 2a. Lower seat
3. Plug locknuts
4. Spring washer
5. Plug
- 5a. Stem joint
6. Stem
7. Bonnet
8. Guide bush
9. Body gasket
10. Packing spring
11. Packing washer
12. Packing rings
13. Internal "O" ring
14. External "O" ring
15. Packing adjusting nut
16. Stud-bolts
17. Body locknuts
18. Yoke
19. Travel indicator plate
20. Position indicator locknuts
21. Position indicator
22. Diaphragm rod
23. "O" ring
24. Airtight
25. Yoke gasket
26. Lower diaphragm casing
27. Lower diaphragm casing internal bolts
28. Diaphragm spacer
29. Diaphragm
30. Diaphragm plate
31. Springs
32. Diaphragm bush
33. Diaphragm locknut
34. Diaphragm casing bolts
35. Upper diaphragm casing
36. Diaphragm casing locknuts

### MATERIALS

1. See note (1) at page 1
- 1a. C40 carbon steel
2. AISI 316 stainless steel
- 2a. AISI 316 stainless steel
3. AISI 304 stainless steel
4. AISI 304 stainless steel
5. AISI 316 stainless steel
- 5a. AISI 316 stainless steel
6. AISI 316 stainless steel
7. See note (1)-(2) at page 1
8. AISI 304 stainless steel
9. Europil WS 3640 or PTFE
10. AISI 302 stainless steel
11. AISI 304 stainless steel
12. See note (3) at page 1
13. Viton FPM 70
14. Viton FPM 70
15. AISI 303 stainless steel
16. Galvanized steel
17. DIN 934 galvanized steel
18. GGG50 spheroidal c. iron
19. Polycarbonate
20. DIN 936 galvanized steel
21. Aluminium
22. AISI 303 stainless steel
23. NBR
24. NBR
25. Cork – rubber
26. P11 steel
27. DIN 933 galvanized steel
28. Galvanized steel
29. EPDM 70
30. P01 steel
31. C98 UNI 3823
32. AISI 303 stainless steel
33. ISO 7380 galvanized steel
34. DIN 934 galvanized steel
35. P11 steel
36. DIN 933 galvanized steel

## DIMENSIONS in mm.

DN	Ø	A(1)	A(2)	B	C - Bonnet			D	V	V1	Actuator	E	Ø F
					Std	Finned	Bellows						
125	5"	403	425	296	252	435	435	213	166	50	400	144	408
150	6"	450	473	307	258	442	442	213	166	50	500	144	520
200	8"	543	568	333	283	465	465	213	166	50			

A(1) cast iron = PN16-ANSI150-JIS10K A(2) carbon and st. steel = PN16-PN40-ANSI150-ANSI300-JIS10K – JIS20K  
 Specifications given are only indicative and not binding for the manufacturer who reserve the right to carry-out any modifications deemed necessary without prior notice. All data sheets by CONFLOW SpA, are available last update on our internet web site [www.conflow.it](http://www.conflow.it).

**THREE-WAY MIXING CONTROL VALVES**   
**PED 97/23/CE / ATEX 94/9/CE / MACHINERY DIRECTIVE 2006/42/CE**

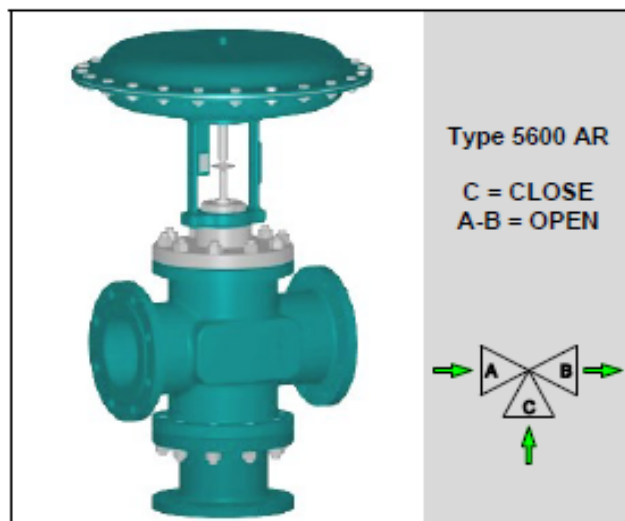

Type 5600 AR

C = CLOSE  
A-B = OPEN

**TYPE 5600 AR** DN 125/200  
Normally closed port "C" on air failure

Face-to-face ASME / ANSI B16.10

**DESCRIPTION**

The "UNIWORLD" series type 5600 AR are equipped with "straight-through" pattern bodies having ANSI face-to-face dimensions and EN - ANSI - JIS flanges.  
 Type 5600 AR three-way mixing control valves (two inlet ports and one outlet port with fluid opens) have a modulating plug suitable for control of virtually all line media.  
 Compact construction assembled with multisprings pneumatic actuator having 3-15 psi ... 6-18 psi ... 6-30 psi standard control signals  
 On request can be equipped with a pneumatic or electro-pneumatic pilot positioner.

**SIZES :** from DN 125 to DN 200

**BODY CONNECTIONS :** flanged EN 1092-1 PN16 PN40  
 flanged ANSI B 16.5 150 RF 300 RF  
 flanged JIS B2220 10K 20K

**MATERIALS OF BODY GROUP (1) :**

- Cast iron EN-GJL-250 UNI EN 1561 PN 16 ANSI 150 JIS 10  
 AISI 316 st. st. trim - C40 nickel plated steel bonnet
- Carbon steel ASTM A216 WCB PN16/40 ANSI 150/300 JIS10/20  
 AISI 316 st. st. trim - C40 nickel plated steel bonnet
- Stainless steel AISI 316 CF8M PN16/40 ANSI 150/300 JIS10/20  
 AISI 316 st. st. trim - AISI 316 st. st. bonnet

**PLUG**

- LV = linear class IV\*
- VPT= quick lift class IV\*

**BONNET (2) :**

- Standard : -5 to +200 °C
- Finned : > 200 °C
- Extended : below -5 °C
- Bellows sealed : for thermal oil or hazardous media with standard safety gland arrangement

**GLAND ARRANGEMENT (PACKING) (3) with safety "O-rings" :**

- PTFE 100% for temperatures ≤150 °C
- PTFE 85% + GRAPHITE 15% for temperatures ≤ 200 °C
- PURE GRAPHITE 100% for temperatures from 200° to 400 °C to be used with finned bonnet

**CV = american unit (flowrate in USGPM with 1 psi of differential pressure)**

**TECHNICAL CHARACTERISTICS OF PNEUMATIC ACTUATOR :**

- Actuator : diaphragm type
- Control signals : 3-15 psi ... 6-18 psi ... 6-30 psi
- Max air supply pressure : 35 psi (2,5 bar)
- Ambient temperature : -20 ... +70 °C \*see on request
- Actuator casings material : Fe P11 carbon steel
- Diaphragm material : EPDM 70
- Yoke material : EN-GJS500-7 spheroidal cast iron
- Pneumatic connections : ISO 7 Rp - 1/8"

**MAX WORKING CONDITIONS :**

- Max inlet pressure and temperature : see leaflet n° 101/VP
- Valve sizing : see leaflet n° 100/VP
- Rangeability : see leaflet n° GRAFIC/I

**ON REQUEST :**

- PTFE/GR soft seal ≤190°C class VI\*
- PTFE soft seal ≤150°C class VI\*
- Lapping on seat and plug class V\*
- Stellite (degree 6°) on seat and plug and guide bush
- Reduced bore (see below table)
- Pneumatic pilot positioner 3-15 psi...3-9 psi...9-15 psi
- Electro-pneumatic pilot positioner 4-20 mA...4-12 mA...12-20 mA
- Air filter regulator
- Proximity limit switches
- 3-way solenoid valve
- Lubrificator on finned bonnet for temperatures ≥ 250 °C
- Top-work manual handwheel
- ATEX 94/9/CE dedicated configuration according to the fluid
- Kit diaphragm and actuator seals certified for a.t. ≥ -50 °C

**Kv = metric unit (flowrate in m3/h with 1 bar of differential pressure)**

PLUG		DN125		DN150		DN200	
Full bore		Ø 5"		Ø 6"		Ø 8"	
LV	CV	290.9		357.3		578.1	
	KV	250.8		308		498.3	
VPT	CV	355.3		429.8		658.6	
	KV	306.3		370.5		567.7	
Reduced bore *		3"	4"	4"	5"	5"	6"

\* CV and KV values are referred to the selected diameter and plug type

**Maximum permissible pressure drops in Kg/cm<sup>2</sup> (fluid opens)  
Strokes in mm – Signals in psi**

Actuator type	Signal psi	DN125	DN150	DN200
		Stroke 60	Stroke 60	Stroke 60
T400	3-15 psi	0,9	0,65	0,35
	6-18 psi	1,85	1,3	1,05
	6-30 psi	4,5	3,2	1,8
T500	3-15 psi	1,55	1,1	0,95
	6-18 psi	3,1	2,2	1,25
	6-30 psi	5,5	4	2,2

1. The values given are referred to the force of actuator and they can be used within the limit of the body rating
2. The actuator DELTA-PI (PRESSURE DROPS with CLOSED VALVE) are obtained without a residual thrust of air into the actuator
3. The actuator DELTA-PI given in the column 6-30 psi are also valid for ON-OFF service with air supply at 30/35 psi

**COMPONENTS LIST AND MATERIALS**

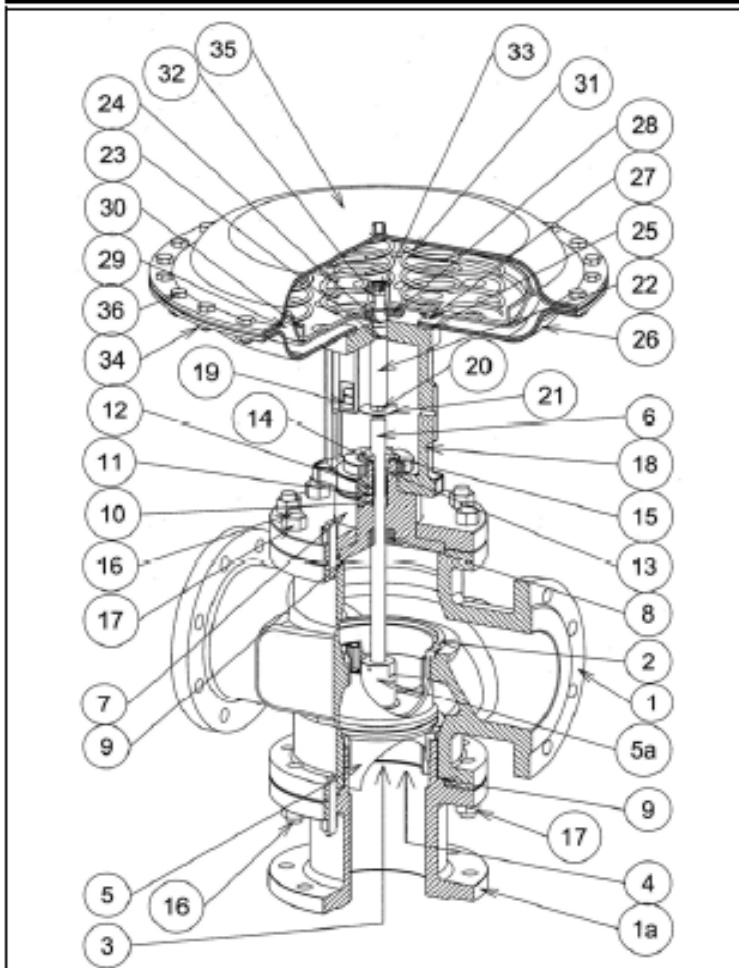

**COMPONENTS LIST**

1. Body
- 1a. Stud pipe
2. Upper seat
- 2a. Lower seat
3. Plug locknuts
4. Spring washer
5. Plug
- 5a. Stem joint
6. Stem
7. Bonnet
8. Guide bush
9. Body gasket
10. Packing spring
11. Packing washer
12. Packing rings
13. Internal "O" ring
14. External "O" ring
15. Packing adjusting nut
16. Stud-bolts
17. Body locknuts
18. Yoke
19. Travel indicator plate
20. Position indicator locknuts
21. Position indicator
22. Diaphragm rod
23. "O" ring
24. Airtight
25. Yoke gasket
26. Lower diaphragm casing
27. Lower diaphragm casing internal bolts
28. Diaphragm spacer
29. Diaphragm
30. Diaphragm plate
31. Springs
32. Diaphragm bush
33. Diaphragm locknut
34. Diaphragm casing bolts
35. Upper diaphragm casing
36. Diaphragm casing locknuts

**MATERIALS**

1. See note (1) at page 1
- 1a. C40 carbon steel
2. AISI 316 stainless steel
- 2a. AISI 316 stainless steel
3. AISI 304 stainless steel
4. AISI 304 stainless steel
5. AISI 316 stainless steel
- 5a. AISI 316 stainless steel
6. AISI 316 stainless steel
7. See note (1)-(2) at page 1
8. AISI 304 stainless steel
9. Europil WS 3640 or PTFE
10. AISI 302 stainless steel
11. AISI 304 stainless steel
12. See note (3) at page 1
13. Viton FPM 70
14. Viton FPM 70
15. AISI 303 stainless steel
16. Galvanized steel
17. DIN 934 galvanized steel
18. GGG50 spheroidal c. iron
19. Polycarbonate
20. DIN 936 galvanized steel
21. Aluminium
22. AISI 303 stainless steel
23. NBR
24. NBR
25. Cork – rubber
26. P11 steel
27. DIN 933 galvanized steel
28. Galvanized steel
29. EPDM 70
30. P01 steel
31. C98 UNI 3823
32. AISI 303 stainless steel
33. ISO 7380 galvanized steel
34. DIN 934 galvanized steel
35. P11 steel
36. DIN 933 galvanized steel

**DIMENSIONS in mm.**

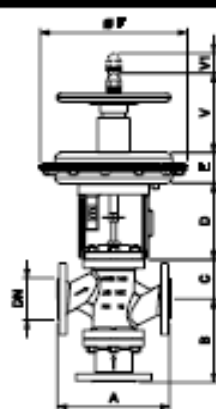

DN	Ø	A(1)	A(2)	B	C - Bonnet			D	V	V1
					Std	Finned	Bellows			
125	5"	403	425	296	252	435	435	213	166	50
150	6"	450	473	307	258	442	442	213	166	50
200	8"	543	568	333	283	465	465	213	166	50

Actuator	E	Ø F
400	144	408
500	144	520

A(1) cast iron = PN16-ANSI150-JIS10K A(2) carbon and st. steel = PN16-PN40-ANSI150-ANSI300-JIS10K – JIS20K  
Specifications given are only indicative and not binding for the manufacturer who reserve the right to carry-out any modifications deemed necessary without prior notice. All data sheets by CONFLOW SpA, are available last update on our Internet web site