

MT4000 Series

SERVO MOTORS FOR AIR DAMPERS AND BUTTERFLY VALVES

INSTRUCTION SHEET



APPLICATION

The MT4000, MT4001, MT4002 and MT4003 are servo motors to control and govern air lock of gaseous and liquid fuels.

The servo motors are suitable in burners with small to medium capacity.

SPECIFICATIONS

Models

MT4000A series for combustion air dampers and VF5000 butterfly valves. External signals for modulation required.

MT4000B series for combustion air dampers and VF5000 butterfly valves. Including relay for one external modulation input.

MT4001A series for air dampers in gas burners. To be used with full featured ignition controllers and 3 wire thermostats.

MT4001B series for air dampers in gas burners. To be used with full featured ignition controllers and 2 wire thermostats.

MT4001C series can be used with satronic TMG740. The ignition controller is providing the burner sequence, including the drive to high fire during pre-purge.

MT4002B series for air dampers in oil burners. Including relay for 2 wire thermostat connection.

MT4003C series can be used with standard low featured ON/OFF ignition controllers, where the pre-purge is provided by the servomotor. Including relays for 2 wire thermostat connection, low fire adjustment switch and fail safe pre-purge timer.

Dimensions

See Fig. 1. Installation drawing MT4000 Series

Supply voltage

Line voltage: 220 ... 240 Vac, 50/60 Hz
110 Vac, 50/60 Hz

Maximum voltage

Current of micro-switches: 250 Vac, 10A (ac) and 2A(dc)

Ambient temperature range

-15 ... 60 °C

Relative humidity: 0 - 90% at 40 °C (non-condensing)

Rated torque value

Maximum torque at 6s rotation time over 90 degrees: 1.5 Nm

Maximum torque at 12s rotation time over 90 degrees: 1.5 Nm

Maximum torque at 24s rotation time over 90 degrees: 3.0 Nm

Maximum diagonal force

300N, when mounted with 4 screws

Stroke timing over 90 degrees

6, 12, 24 and 30 s at 50 Hz

At 60 Hz, the timing is reduced with approximately 20%

Maximum adjustable stroke

0 to 160 degrees

Enclosure

IP40

Minimum camshaft step

2 degrees (including mechanical tolerances)

Electrical connection

Two PG9 wiring conduits are provided in the housing.

NOTE: Do not provide strain-relief according to EN60730

Finish

The servo motor is mounted in a black housing and transparent plastic cover, which can be removed by loosening 2 screws.

Pre-purge timer (MT4003C only)

20 seconds, tolerance -0 s, +10 s.

Design life

Model	Number of Cycles
All models MT4000 Series	250.000

Standards and approvals

The MT4000 Series conform with the following EC directives:

- Low Voltage Directive (73/23/EEC)
PIN: 0063AR1582
- Electro Magnetic Compatibility Directive (89/336/EEC)
- EN298 for MT4003C with pre-purge timer

INSTALLATION

IMPORTANT

1. Installer must be a trained experienced service man.
2. Disconnect power supply to prevent electrical shock and/or equipment damage.
3. When the MT4000 is used in stand alone applications, use a proper strain-relief
4. The appliance manufacturer's instructions should be followed when provided.
5. Carry out a thorough checkout when installation is completed.

Low fire adjustment switch (optional)

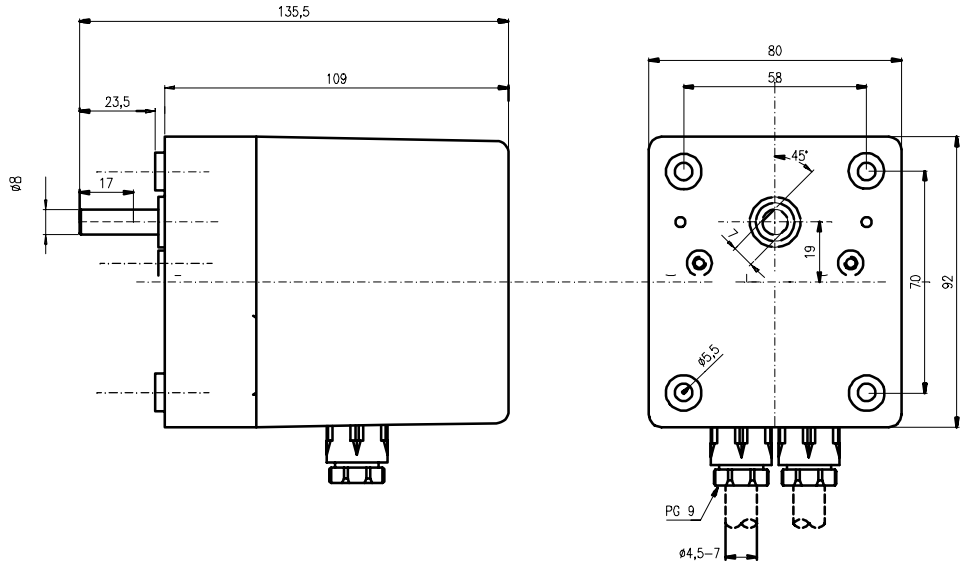
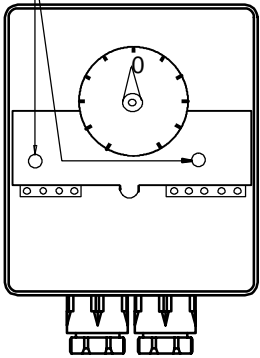

Fig. 1. Installation drawing MT4000 Series

Mounting and orientation

There are no restrictions in the mounting angle of the motor. The motor can be assembled by 4 screws. For mounting hole dimensions, see installation drawing.

ADJUSTMENT AND CHECKOUT

WARNING

- Adjustment should be made by qualified personnel only.
- If the appliance manufacturer supplies checkout and/or service and maintenance instructions, carefully follow them.
- All adjustments on the cams should be done *after* disconnecting the power supply.

Functions of cams:

MT4000 A/B series		MT4001 A/B/C, MT4002B & MT4003C series	
cam		cam	
I	high fire position of air damper motor	I	high fire position of air damper motor
II	closed position of the air damper motor	II	closed position of air damper motor
III	auxiliary switches	III	low fire position of air damper motor
IV	auxiliary switches	IV	low fire position of air damper motor
		V	switches the second stage operation of the gas valves

Adjustment for cams

Disconnect power supply and remove the cover. Use adjustment tool inside the cover to adjust the cams. Place the tool in one of the cam grooves to turn the cam in steps of approximately 2 degrees.

Factory set "zero position"

All motors are factory set with zero position corresponding with 45 degrees angle of flat surface on actuator shaft (see figure 1.). When field re-adjustment of zero position is necessary, rotate cam II (clock or counter-clockwise) to zero position and re-adjust arrow on scale manually.

Low fire adjustment switch (optional)

A push button switch, to activate electrically movement of the cam assembly, independent from the flame relay signals, is optional on MT4001B, MT4001C, MT4002B and MT4003C type of servo motors. Use the push button switch to move the cam assembly forward during (re)adjustment of the low fire position of the damper. When this push button is pressed down, the motor will drive to high fire position. When the push button is released, the motor will drive to low fire position. Depending on type, it is positioned either on left or right side of the front plate.

Cam adjustment for servo motors with right hand rotation

Cam adjustment for servo motors with left hand rotation

MT4000A/B series		MT4000A/B series	
cam		cam	
I/III & IV	Rotate the cam clockwise to increase the opening position of the air damper Rotate the cam counter-clockwise to decrease the opening position of the air damper	I/ III & IV	Rotate the cam counter-clockwise to increase the opening position of the air damper Rotate the cam clockwise to decrease the opening position of the air damper
II	Factory set at 0 degrees, to start air damper in closed position	II	Factory set at 0 degrees, to start air damper in closed position
MT4001A/B/C, MT4002B & MT4003C series		MT4001A/B/C, MT4002B & MT4003C series	
cam		cam	
I	Rotate the cam clockwise to increase the high fire position of the air damper Rotate the cam counter-clockwise to decrease the low fire position of the air damper	I	Rotate the cam counter-clockwise to increase the high fire position of the air damper Rotate the cam clockwise to decrease the low fire position of the air damper
II	Factory set at 0 degrees, to start the air damper in closed position	II	Factory set at 0 degrees, to start the air damper in closed position
III/IV	Rotate cam clockwise to increase the low fire position of air damper Rotate cam counter-clockwise to decrease the low fire position of the air damper	III/IV	Rotate cam counter-clockwise to increase the low fire position of air damper Rotate cam clockwise to decrease the low fire position of the air damper
V	Rotate the cam clockwise, to delay the switching of the second stage gas valve Rotate the cam counter-clockwise, to advance the switching of the second stage of the gas valve	V	Rotate the cam counter-clockwise, to delay the switching of the second stage gas valve Rotate the cam clockwise, to advance the switching of the second stage of the gas valve

ELECTRICAL CONNECTIONS

IMPORTANT

Protective earth wires of external connected devices etc. should be connected to the MT4000 earth terminal according the manufacturer's instructions (max. 2 devices)

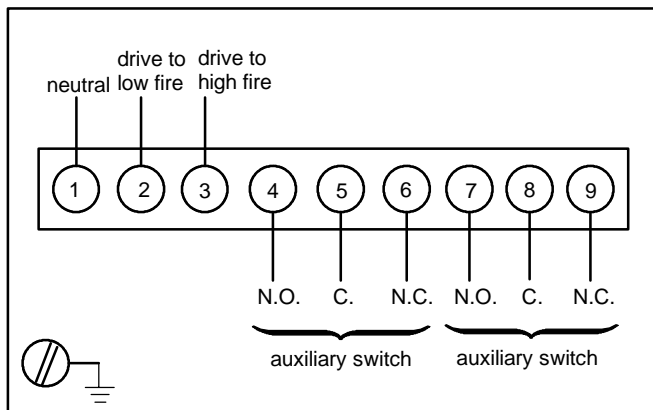

Fig. 2. Wiring Diagram MT4000A

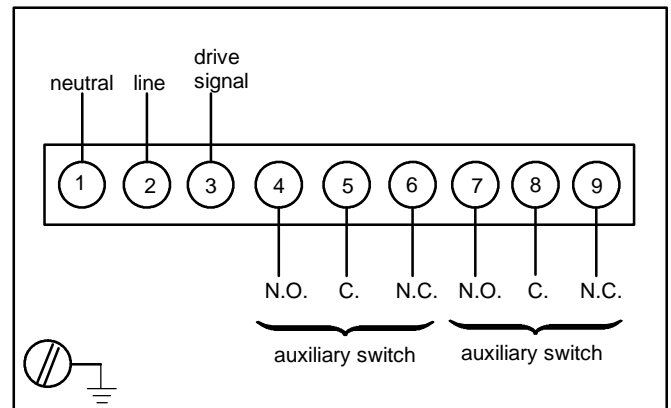

Fig. 3. Wiring Diagram MT4000B

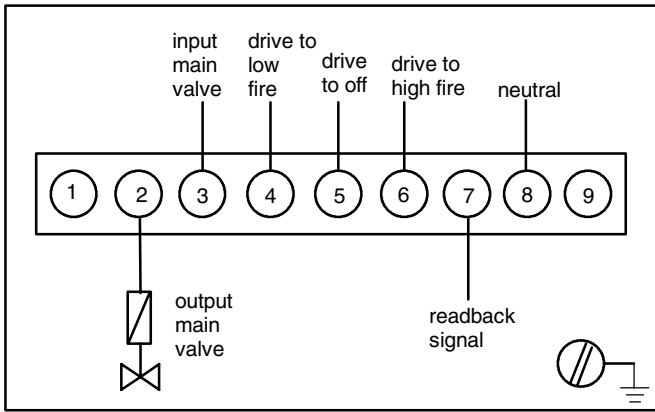

Fig. 4. Wiring Diagram MT4001A

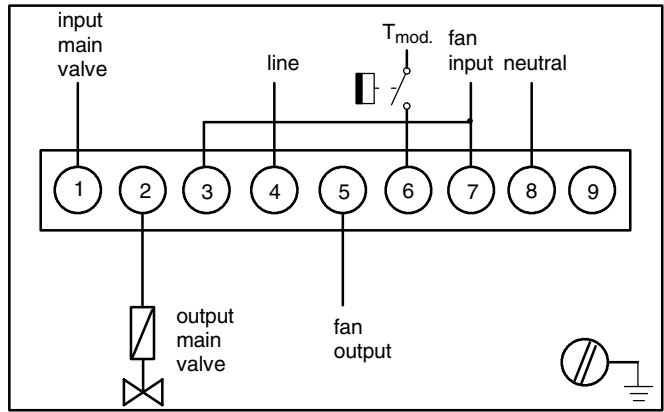

Fig. 8. Wiring Diagram MT4002B

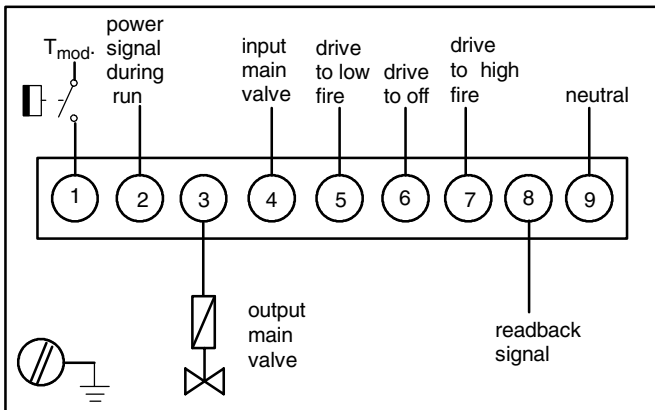

Fig. 5. Wiring Diagram MT4001B

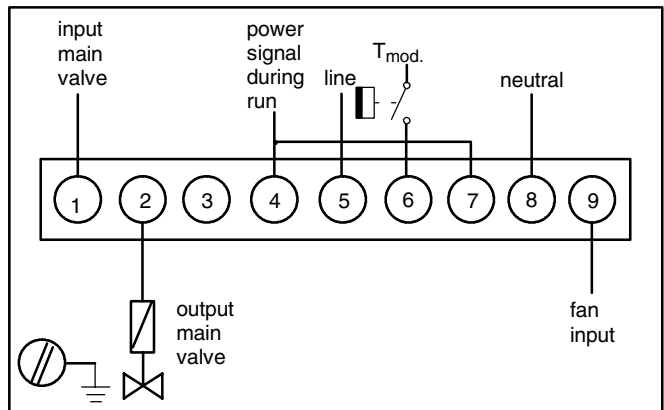

Fig. 9. Wiring diagram MT4003C

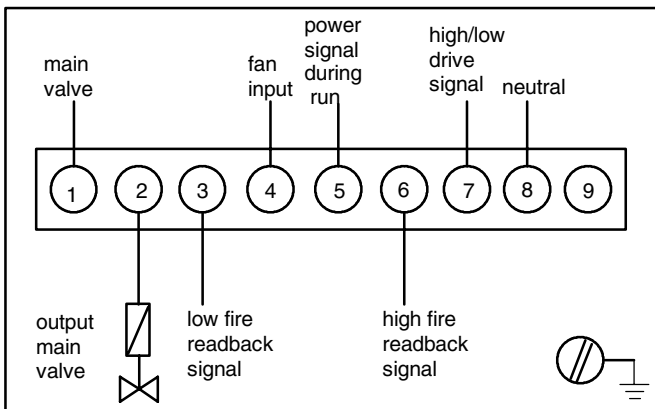

Fig. 7. Wiring diagram MT4001C

Honeywell

Automation & Control Solutions

Control Product
 Satronic AG
 Honeywell-Platz 1
 CH-8157 Dielsdorf
 Switzerland
 Phone: +41 1 855 22 11
 Fax: +41 1 855 22 22
 EN2C-0035SZ20 R0604



Travessa da Prelada, n.º 106 | 4250-379 Porto
 GPS N41.169040 W8.630748
 Tel: 228 305 348/422 | Tlm: 964 096 068 | Fax: 228305425
 www.sertequi.pt | geral@sertequi.pt